

VAR B: SHORT PRODUCT DESCRIPTION

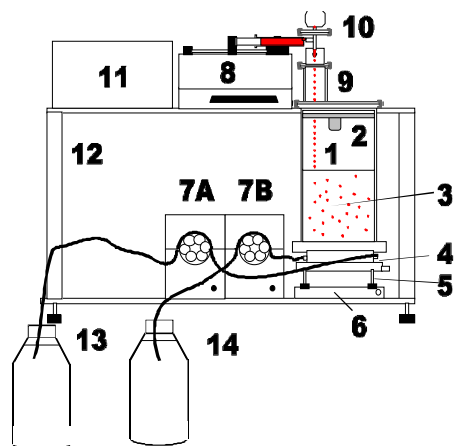

Overview



Short Description

This is an electromagnetically driven sterile single nozzle unit based on the laminar-jet-breakup. The unit with its sophisticated multipurpose design and the flexible modular expandability has been tailored to the process developer's requirements. The modular approach in the design allows to change the unit repeatedly according to the changing requirements and to combine components delivered by us with equipment and devices already available in your laboratory. The number of standard options available is impressive.

Legend:

- | | |
|---------------------------------------|--|
| 1 Autoclavable working vessel | 8 Syringe pump |
| 2 Bypass system | 9 Sightglass with stroboscopic light |
| 3 Hardening solution / level switches | 10 Vibrator |
| 4 Bottom with 2 injection ports | 11 Control cabinet |
| 5 Levelling device | 12 Base frame made of stainless steel |
| 6 Laboratory agitator | 13 Flask for hardening solution, feed |
| 7A Peristaltic pump for feed | 14 Flask for hardening solution, retract |
| 7B Peristaltic pump for retracting | Pos. 7, 13, 14 are not included in scope of supply |

Applications:

For a large number of applications (e.g. enzyme/drug immobilisation, cell encapsulation, cosmetic applications and many more), microencapsulation opens new technological possibilities.

Principle

The unit has a single vibrating nozzle (frequency and amplitude can be adjusted digitally). A syringe pump produces a steady pulsation-free flow through the vibrating nozzle. The generated drops can be observed by means of an LED-stroboscopic light as a stationary chain of drops. The stroboscopic light is automatically synchronised with the adjusted vibration frequency. Monodisperse beads of the size between 0.2 and 1.5mm can be generated. The deviations between the applications mainly depend on the viscosity and the surface tension the matrix. Roughly, you can estimate that the smallest achievable drop diameter is 1.5 to 2 times larger than the used nozzle diameter. The average productivity per nozzle is 400ml per hour, whereas this can significantly differ in function of the nozzle diameter and the jet speed. The unit can be sterilised in an autoclave. The system is designed for a typical size of 280ml.

Control Cabinet

- | | |
|---|--|
| <input checked="" type="checkbox"/> Rack with display, four lines x 16 characters, programmable micro controller for vibration control and stroboscopic light | <input checked="" type="checkbox"/> Power supply between 110 V and 240 Volt, automatically adjusting |
|---|--|

For more details please contact:

Nisco Engineering Inc.
Wehtalerstrasse 562
CH-8046 Zurich, Switzerland

Tel. +41 44 380 06 30
Fax +41 44 380 06 31
e-mail mailbox@nisco.ch, www.nisco.ch