

VAR C: SHORT PRODUCT DESCRIPTION

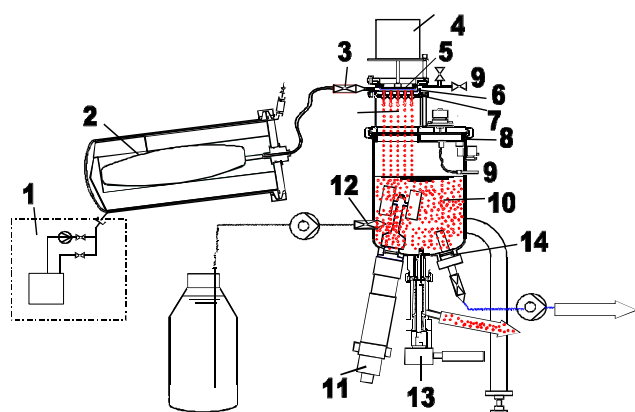

Overview



Short Description

The small sterile plant with 13 nozzles meets the requirements of an industrial production of small batches. The plant can be adjusted to the changing requirements of the user. The modular design approach allows combining equipment delivered by Nisco with components already available at the user's facility.

Legend

- | | |
|---------------------------------|---------------------------------------|
| 1 Auxiliary pumping system | 8 Bypass system with CIP |
| 2 Lineaseptaï bag pump | 9 CIP system connection |
| 3 Septum connection feed | 10 Reaction vessel |
| 4 Vibrator | 11 Stirrer |
| 5 Membrane of pulsation chamber | 12 Septum hardening solution feed |
| 6 Pulsation chamber | 13 Bottom valve |
| 7 Nozzle plate | 14 Filtration unit hardening solution |

Applications

For a large number of applications (e.g. enzyme/drug immobilisation, cell encapsulation, cosmetic applications and many more), microencapsulation opens new technological possibilities.

Principle

The Lineaseptaï bag pump produces a steady pulsation-free flow to the vibrating chamber. The bead generating unit has 13 nozzles. The vibration is superimposed on the product feed in the vibrating chamber by means of a membrane (frequency and amplitude can be adjusted digitally). The generated drops can be observed by means of an LED-stroboscopic light as 13 stationary chains of parallel drops. The stroboscopic light is automatically synchronised with the adjusted vibration frequency. Monodisperse beads of the size between 0.2 and 1.5mm can be generated. The deviations between the applications mainly depend on the viscosity and the surface tension of the matrix. Roughly you can estimate that the smallest achievable drop diameter is 1.5 to 2 times larger than the used nozzle's diameter. The average productivity per nozzle is 400ml per hour, whereas this can significantly differ in function of the nozzle diameter and the jet speed. The unit can be sterilised in an autoclave. The typical batch size is 1 to 2 litre.

Control Cabinet

- | | |
|---|--|
| <input checked="" type="checkbox"/> Rack with display, four lines x 16 characters, programmable micro controller for vibration control and stroboscopic light | <input checked="" type="checkbox"/> Power supply between 110 V and 240 Volt, automatically adjusting |
|---|--|

For more details please contact:

Nisco Engineering Inc.
Wehtalerstrasse 562
CH-8046 Zurich, Switzerland

Tel. +41 44 380 06 30
Fax +41 44 380 06 31
e-mail mailbox@nisco.ch, www.nisco.ch